Mobile Field Hospitals



History

The Mobile Field Hospitals has been used by the Dutch Army and was made to a NATO Role 2 Field Hospital standards. With protection against nuclear, biological and chemical attacks (NBC function).

These were specifically developed for war situations, peace enforcement and peace keeping. They were made according to STANAG 2895 qualification (working conditions between +49 degrees and -32 degrees Celsius).

General structure

The mobile field hospitals include the following containers (13 in total):

- 1 container with 2x 96 KVA generator inside (EN Shelter)
- 1 container for Airco and Oxygen (AI Shelter)
- 2 containers for surgical use (with slide outs) (OK Shelter)
- 3 containers for Intensive care (with slide outs) (PP Shelter)
- 1 container for Xray (no Xray system inside) (RO Shelter)
- 1 container for storage of medical supplies (MA Shelter)
- 4 containers to link the containers together (KO Shelter)

TECHNICAL SPECS EN-SHELTER

2 Generators	CUMMINS turbo-dieseleengine	6 cilinder, 4-takt.
		5,9 l, 86 kW (115 bhp)
		cons. max. ca. 20 l/h (max. power)
	MARELLI generator	230/400 V, 50 Hz 87 kVA
	Size diesel tanks	2 x 255 l, with cross- feed (for min. 12 hrs max. power)
	Emergency start connection	24 VDC 200 A
	Heat-power connection with AI- shelter	Capacity ca. 120 kW
Connection external power	Ca. 230 kVA, 230/400 VAC \pm 5%, 50 Hz	5 connections: 3 fase, 1 neutral, 1 earth
Energy distribution system	Connection for 18 cables (65 m, 50 m en 40 m)	Connections 230/400 VAC 50 Hz

TECHNICAL SPECS AI-SHELTER

Air System	3 compressors	Temperature: +18° - +30° C
	2 main-pumps	Relative humidity: 25-60% to KO/MA-shelters 500 l.
	1 emergency pump	
	Electrical heater Heat-power connection with EN-Air humidifier	
	System buffer	
Energy		Max. consumption electrical power:
		16,4 kW in winter mode
		85 kW in summer mode
Medical Gasses	Oxygene installation	2 batteries with each 3 x 4.000 l and 9 x 4.000 l stock (at 1 bar) - workload 5 bar
	Supply breathing air installation	3-way compressor, 190 l/min. Buffer 40.000 l (at 1 bar)

TECHNICAL SPECS KO-SHELTER

Energy Supply		Max. electrical consumption: 7,8 kW in winter mode 2,7 kW
Water Supply	Watertank with UV-installation pressurized	In summer mode 800 l
	watertank centrifugal pump	20 l
		4m ³ per hour, 1-5 bar

TECHNICAL SPECS MA-SHELTER

Cabinets medical storage		ca. 6,25 M3
Energy		Max. electrical consumption: 7,8 kW in winter mode 2,7 kW in summer mode

TECHNICAL SPECS OK-SHELTER

Energy		Max. electrical consumption: 10,2 kW in winter mode 15 kW in summer mode 6480 w emergency batteries
Air System	Humidifier	Relative humidity: 50-65%
Water supply	Boiler waste watertank	10 l, 80° C (time to heat ca.24 min.) 400 l

TECHNICAL SPECS PP-SHELTER

Energy		Max. electrical consumption: 9,8 kW in winter mode 12,7 kW in summer mode 4320 w emergency batteries
Air system	Humidifier	Relative humidity: 25-60%
Water supply	Boiler waste watertank	10 l, 80° C (time to heat ca.24 min.) 400 l

TECHNICAL SPECS RO-SHELTER

Energy		Max. electrical consumption: 12,7 kW in winter mode 13,8 kW in summer mode 4320 w emergency batteries
Air system	Humidifier	Relative humidity: 25-60%
Water supply	Boiler waste watertank	10 l, 80° C (time to heat ca.24 min.) 400 l

Load Capacity of the roof

Weight (N)	Area (M)	Remarks
1000	Complete roof	Evenly distributed on the roof
3000	0,3 x 0,6	Anywhere on the roof
4000	0,8 x 1	Anywhere on the roof

Wind limitations

Wind speed (m/s)	Wind force (Bf)	Wind gusts (m/s)	Limitation
13,3-17,1	7		Max. wind speed where the shelters can be set up without limitations. OK/PP/RO-shelters slide out with 3 men instead of 2 men. Keep the doors of the shelters closed as much as possible. Don't use wind hooks
Above 17,5			Don't set up the shelters
28	10	53	Max. wind speed where you can use the shelters

Additional information

Quantities:

- ~~-13 shelters from hospital 1~~ SOLD
- 13 shelters from hospital 2
- 13 shelters from hospital 3

Each container can be transported on a normal 20ft container chassis. Or you can transport 2 containers on a 40 ft container chassis. They have got hydraulic leveling. In order to take them off the chassis, you need to use a crane. The heaviest container weighs about 12 Tonnes (EN Shelter).

The Mobile Hospital is made to the highest standards and was made to have the same air quality as a normal civilian Dutch hospital. All the containers are linked together to create overpressure inside, keeping bacteria outside. The air filters throughout the hospital, are all air filtering systems.

Additional information (2)

Further there is a mode in which the hospital can be used during a Nuclear, Biological and Chemical attacks.

The generators can provide the hospital with electricity. There is also a possibility to use external power or use own generators. Each generator has got a 255 liter diesel tank. In case of a power loss, the containers with slide outs, have got their own batteries, making sure there is power for another 3 hours.

It is possible to connect the hospital to an external water source. Or the system can be filled with water by a tank truck. The water is purified with the internal UV system. Inside every KO-Shelter there is a water tank of 800 liters.

There is the possibility to perform 12 surgeries per day per operating shelter, in an air quality environment equal to a normal civilian Dutch hospital. In total there is capacity for up to 12 Intensive Care beds (4 per PP-shelter).

The Containers must be set up on a flat-even surface. There is a space needed of about 30m x 30m.

Every shelter has got all the equipment inside to connect them to another shelter. So they all have a electric leveling system, and tools and pipes and cables to fix everything together.

Beside this, you also get NBC filters that are expired, but they are in a vacuum packaging. There are about 20 of these. All shelters have got their own support legs and plates for underneath the support legs. The movie that you have received tells you everything that is inside and included in this offer.

Additional workbooks & instruction manuals

With the hospitals you also get all the documentation available for technical support. These are thousands of pages with drawings (electrical wirings, drawings of the units etc.) These are pdf-files in Dutch language but are easy to translate in your own language.

So full documentation for every part of the system and also maintenance en set-up schedules are available. Then can be send electronically to the person you choose.

There are 6 big manuals:

1. Manual on how to operate the complete hospital (624 pages)
2. Manual on the shelters (216 pages)
3. Manual on how to use the air installation (430 pages)
4. Manual on the energy systems (516 pages)
5. Manual on the water management (130 pages)
6. Manual on the medical systems (120 pages)

Additional workbooks & instruction manuals (2)

Further:

- Final System plan with all NSN numbers and practical information (how to transport, budget spend on the hospitals etc.)
- Instruction card per shelter and instruction cards for water management en air treatment etc.
- Inspection card per shelter with maintenance instruction.
- Regular maintenance scheme with the amount of time used.
- Electrical schemes of almost everything.
- Function description of all people involved at the army (over 200 files).

Benefits

What are the main benefits of using our mobile field hospital based in containers over a field hospital in tent structures:

	Container	Tent
Hygiene	Overpressure, (HEPA) Filtering in every shelter	Less high standard
NBC protection	Special NBC filtering integrated in the whole hospital	No filtering
Climatization	Insulated thick walls, -32 to +49 degrees Celsius and extreme wind	A piece of fabric to hold the cold, warmth and wind outside....
Maintenance	Solid long-lasting materials, easy to clean	Dust issues
Set up	Very fast, modular configuration, hydraulic levelling, everything already inside incl. power generators.	More preparation underground needed. Difficult to roll equipment in.
Durability	Made to last more than 30 years	Less durable
Flexibility	Several (compact) hospitals or huge hospital configuration, all possible.	1 size

Benefits (2)

The hygiene is much better. Our system has got an overpressure system and all kinds of filtering throughout the whole field hospital, giving it the same air quality as a normal civilian Dutch hospital. It is far better than any tent structure can give.

Also there is a NBC (nuclear, biological and chemical) function to give more protection, than any tent hospital will ever give against this form of attack. The will then be filtered through special NBC filters.

The climatization is very important. Our field hospital was designed to be used in temperature from minus 32 degrees Celsius till plus 49 degrees Celsius according to the STANAG NATO rules. The shelters are made from aluminium and the walls are better insulated than any tent will ever be.

The way and materials used in our shelters, give it far less maintenance than a tent hospital. Everything is made of very durable long-lasting material that is easy to clean.

There is no tent structure with this amount of capacity that will be set up faster than our shelters. In fact, it will not even be a close battle. Our shelters have all got individual hydraulic support legs, that automatically level themselves on the ground. This way you can work on several shelters at the same time, and you can overcome some height differences on a rough terrain. With tents you have to even the ground completely before you can even think of setting it up.

The shelters are already equipped with everything that is needed inside. So, there is no need to get the hospital beds from a different location or any other items that are needed. You have the cabinets already pre-installed and all the air filtering, water tanks, surgical lamps etc.

Benefits (3)

The shelters are so much more long-lasting. As said, they are made of aluminum, designed to last many decades. In a war situation you need good material, and these are so much more durable and stronger. In a tent it is way easier to get damage on the fabric, because of people running in and out.

In the end you need less preparation and coordination before using our mobile field hospital. The shelters contain everything that is needed inside and can be build up modular in different configurations. It is also possible to make smaller hospitals like a 4 Shelter set up (1x Surgery Shelter, 1x Intensive Care Shelter, 1x Storage Shelter, 1x Shelter to connect the others), or you can even connect all 3 hospitals making it a hospital with 6 surgical rooms and 36 intensive care beds. All shelters work the same to set up.

It is hard to put the equipment inside, since you have to run it over a plastic floor.

NATO Stock Numbers

UP Shelter Koppel	5895-17-112-6031
UP Shelter Material	5895-17-112-6032
UP Shelter Operationroom	5895-17-112-6033
UP Shelter Pre/Post	5895-17-112-6034
UP Shelter Radiology	5895-17-112-6035
UP Shelter Airco	5895-17-112-6036
UP Shelter Energy	5895-17-112-6037

**The NSN
(NATO) stocknumber
for 1 complete system is :**

5895-17-112-6038

View

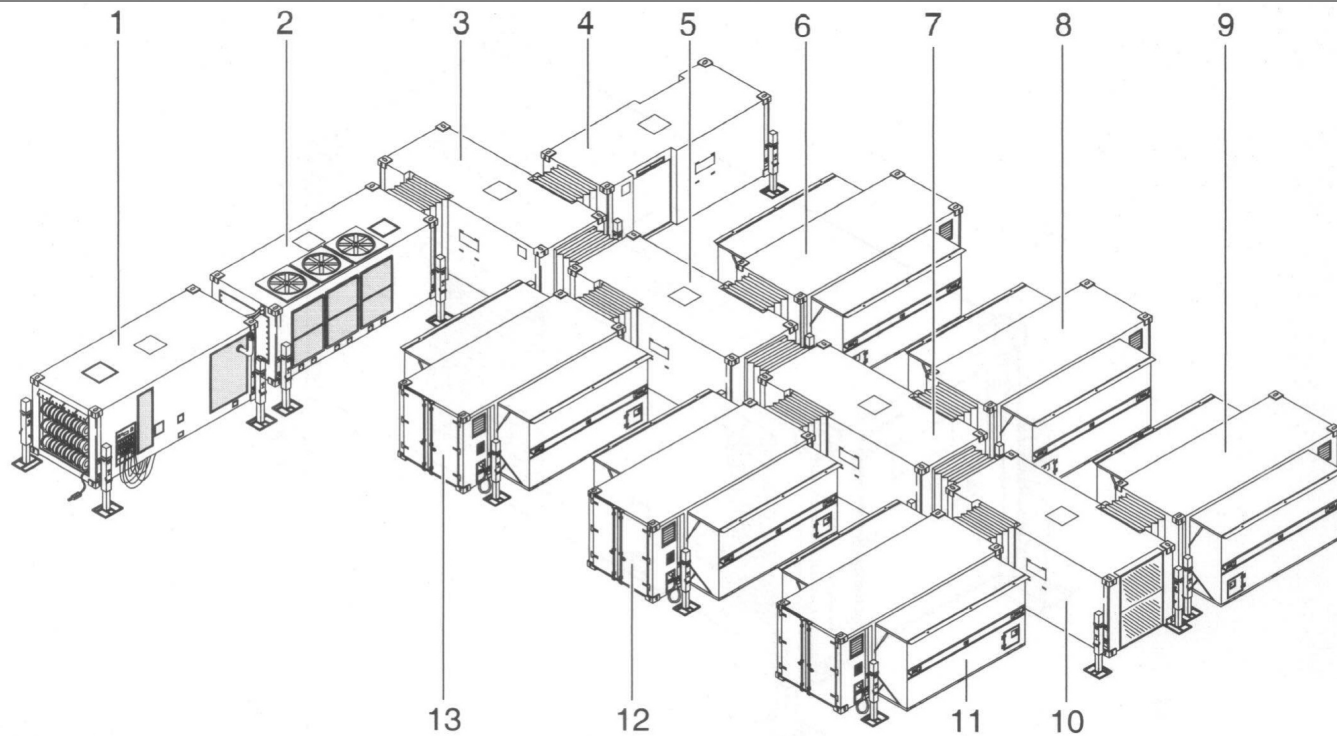

LEGENDA

1.	EN-shelter
2.	AI-shelter
3.	KO-shelter
4.	MA-shelter
5.	KO-shelter
6.	PP-shelter
7.	KO-shelter
8.	RO-shelter
9.	PP-shelter
10.	KO-shelter
11.	PP-shelter
12.	OK-shelter
13.	OK-shelter

Dimensions

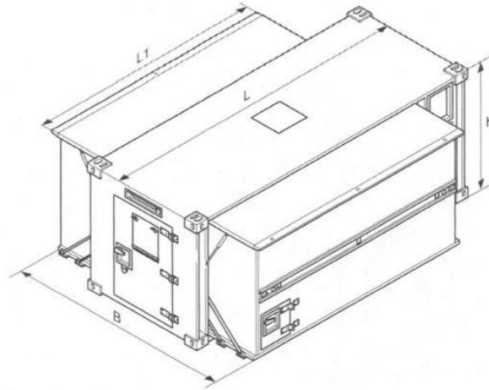

OK/PP/RO

	OK	PP	RO
Length (L) Outside	6055 mm	6055 mm	6055 mm
Length (L) Inside	5925 mm	5925 mm	5925 mm
Length (L1) Inside	4450 mm	4450 mm	4450 mm
Width (B) Outside	4377 mm	4377 mm	4377 mm
Width (B) Inside	4275 mm	4275 mm	4275 mm
Height (H) Outside	2435 mm	2435 mm	2435 mm
Height (H) Inside	2300 mm	2300 mm	2300 mm
Weight Loaded (approx)	5740 kg	5100 kg	6165 kg

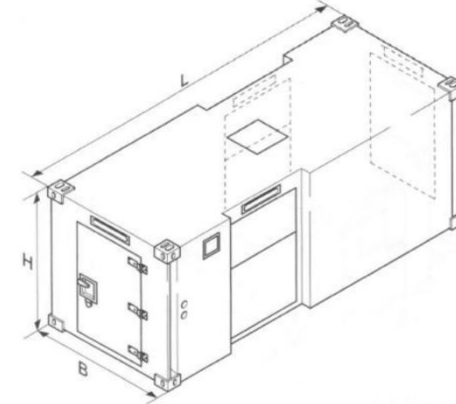

EN/AI/KO/MA

	KO	MA	AI	EN
Length (L) Outside	6055 mm	6055 mm	6055 mm	6055 mm
Length (L) Inside	5925 mm	5925 mm	5925 mm	5925 mm
Width (B) Outside	2435 mm	2435 mm	2435 mm	2435 mm
Width (B) Inside	2300 mm	2300 mm	2300 mm	2300 mm
Height (H) Outside	2435 mm	2435 mm	2435 mm	2435 mm
Height (H) Inside	2300 mm	2300 mm	2300 mm	2300 mm
Weight Loaded (approx)	4290 kg	3620 kg	6900 kg	8240 kg

Impressions



H

Mobile Hospital

4X 20FT CONTAINER



1. Intensive care



3. Storage



2. Operating theatre



4. Corridor

4 CONTAINER HOSPITAL

- 1X operating theatre for up to 12 surgeries per day
- 1X intensive care room for up to 12 beds
- 1X storage room for all medical disposals and equipment
- 1X room to connect all room with 800 l waterstorage



Impressions



Impressions



Final summary

- Total capacity of 24 surgeries per hospital per day possible.
- Fastest set up time for a field hospital. Much quicker than tents or systems with manual leveling.
- Build according to NATO standards with prove of NATO-stock numbers.
- Complete aluminum construction which guarantees no rust and incredible long lifetime (over 30 years!)
- Complete support possible for maintenance and service.
- Complete electric automatic leveling and manual back up system.
- Nuclear, biological and chemical filtering.
- Overpressure and HEPA advanced filtering guarantees air quality from normal civilian Dutch hospital.
No tent or other field hospital available that comes close to this quality.
- These hospitals have extreme little wear & tear.
- Internal water system with UV filtering.
- Own generators with back up batteries and also able to run on external power.
- Modular configuration. Each hospital can be placed anywhere it suits you and as is needed.
It is possible to create 2 separate field hospitals or link everything together as one huge field hospital.
Or create 4 pieces of smaller hospitals.